



Standard Test Methods for Deep Foundations Under Static Axial Compressive Load¹

This standard is issued under the fixed designation D1143/D1143M; the number immediately following the designation indicates the year of original adoption or, in the case of revision, the year of last revision. A number in parentheses indicates the year of last reapproval. A superscript epsilon (ϵ) indicates an editorial change since the last revision or reapproval.

This standard has been approved for use by agencies of the U.S. Department of Defense.

1. Scope

1.1 The test methods described in this standard measure the axial deflection of a vertical or inclined deep foundation when loaded in static axial compression. These methods apply to all deep foundations, referred to herein as *piles*, that function in a manner similar to driven piles or cast-in-place piles, regardless of their method of installation, and may be used for testing single piles or pile groups. The test results may not represent the long-term performance of a deep foundation.

1.2 This standard provides minimum requirements for testing deep foundations under static axial compressive load. Plans, specifications, and/or provisions prepared by a qualified engineer may provide additional requirements and procedures as needed to satisfy the objectives of a particular test program. The engineer in responsible charge of the foundation design, referred to herein as the Engineer, shall approve any deviations, deletions, or additions to the requirements of this standard.

1.3 This standard allows the following test procedures:

Procedure A	Quick Test	8.1.2
Procedure B	Maintained Test (Optional)	8.1.3
Procedure C	Loading in Excess of Maintained Test (Optional)	8.1.4
Procedure D	Constant Time Interval Test (Optional)	8.1.5
Procedure E	Constant Rate of Penetration Test (Optional)	8.1.6
Procedure F	Constant Movement Increment Test (Optional)	8.1.7
Procedure G	Cyclic Loading Test (Optional)	8.1.8

1.4 Apparatus and procedures herein designated “optional” may produce different test results and may be used only when approved by the Engineer. The word “shall” indicates a mandatory provision, and the word “should” indicates a recommended or advisory provision. Imperative sentences indicate mandatory provisions.

1.5 A qualified geotechnical engineer should interpret the test results obtained from the procedures of this standard so as to predict the actual performance and adequacy of piles used in the constructed foundation. See [Appendix X1](#) for comments regarding some of the factors influencing the interpretation of test results.

1.6 A qualified engineer shall design and approve all loading apparatus, loaded members, support frames, and test procedures. The text of this standard references notes and footnotes which provide explanatory material. These notes and footnotes (excluding those in tables and figures) shall not be considered as requirements of the standard. This standard also includes illustrations and appendices intended only for explanatory or advisory use.

1.7 The values stated in either SI units or inch-pound units are to be regarded separately as standard. The values stated in each system may not be exact equivalents; therefore, each system shall be used independently of the other. Combining values from the two systems may result in non-conformance with the standard.

1.8 The gravitational system of inch-pound units is used when dealing with inch-pound units. In this system, the pound [lbf] represents a unit of force [weight], while the unit for mass is slugs. The rationalized slug unit is not given, unless dynamic [F=ma] calculations are involved.

1.9 All observed and calculated values shall conform to the guidelines for significant digits and rounding established in Practice [D6026](#).

1.10 The method used to specify how data are collected, calculated, or recorded in this standard is not directly related to the accuracy to which the data can be applied in design or other uses, or both. How one applies the results obtained using this standard is beyond its scope.

1.11 *This standard does not purport to address all of the safety concerns, if any, associated with its use. It is the responsibility of the user of this standard to establish appropriate safety and health practices and determine the applicability of regulatory limitations prior to use.*

2. Referenced Documents

- 2.1 *ASTM Standards*:²
 - [D653 Terminology Relating to Soil, Rock, and Contained Fluids](#)

¹ This test method is under the jurisdiction of ASTM Committee [D18](#) on Soil and Rock and is the direct responsibility of Subcommittee [D18.11](#) on Deep Foundations.

Current edition approved June 15, 2013. Published July 2013. Originally approved in 1950. Last previous edition approved in 2007 as D1143 – 07^{ε1}. DOI: 10.1520/D1143_D1143M-07R13.

² For referenced ASTM standards, visit the ASTM website, www.astm.org, or contact ASTM Customer Service at service@astm.org. For *Annual Book of ASTM Standards* volume information, refer to the standard’s Document Summary page on the ASTM website.

D3740 Practice for Minimum Requirements for Agencies Engaged in Testing and/or Inspection of Soil and Rock as Used in Engineering Design and Construction

D5882 Test Method for Low Strain Impact Integrity Testing of Deep Foundations

D6026 Practice for Using Significant Digits in Geotechnical Data

D6760 Test Method for Integrity Testing of Concrete Deep Foundations by Ultrasonic Crosshole Testing

2.2 *American National Standards*.³

ASME B30.1 Jacks

ASME B40.100 Pressure Gages and Gauge Attachments

ASME B89.1.10.M Dial Indicators (For Linear Measurements)

3. Terminology

3.1 *Definitions*—For common definitions of terms used in this standard, see Terminology **D653**.

3.2 *Definitions of Terms Specific to This Standard:*

3.2.1 *cast in-place pile, n*—a deep foundation unit made of cement grout or concrete and constructed in its final location, for example, drilled shafts, bored piles, caissons, auger cast piles, pressure-injected footings, etc

3.2.2 *deep foundation, n*— a relatively slender structural element that transmits some or all of the load it supports to soil or rock well below the ground surface, such as a steel pipe pile or concrete drilled shaft

3.2.3 *driven pile, n*—a deep foundation unit made of pre-formed material with a predetermined shape and size and typically installed by impact hammering, vibrating, or pushing.

3.2.4 *failure load, n*—for the purpose of terminating an axial compressive load test, the test load at which rapid continuing, progressive movement occurs, or at which the total axial movement exceeds 15 % of the pile diameter or width, or as specified by the engineer.

3.2.5 *telltale rod, n*—an unstrained metal rod extended through the test pile from a specific point to be used as a reference from which to measure the change in the length of the loaded pile.

3.2.6 *wireline, n*—a steel wire mounted with a constant tension force between two supports and used as a reference line to read a scale indicating movement of the test pile.

4. Significance and Use

4.1 Field tests provide the most reliable relationship between the axial load applied to a deep foundation and the resulting axial movement. Test results may also provide information used to assess the distribution of side shear resistance along the pile shaft, the amount of end bearing developed at the pile toe, and the long-term load-deflection behavior. A foundation designer may evaluate the test results to determine if, after applying an appropriate factor of safety, the pile or pile group has an ultimate static capacity and a

deflection at service load satisfactory to support a specific foundation. When performed as part of a multiple-pile test program, the designer may also use the results to assess the viability of different piling types and the variability of the test site.

4.2 If feasible, without exceeding the safe structural load on the pile(s) or pile cap, the maximum load applied should reach a failure load from which the Engineer may determine the ultimate axial static compressive load capacity of the pile(s). Tests that achieve a failure load may help the designer improve the efficiency of the foundation by reducing the piling length, quantity, or size.

4.3 If deemed impractical to apply axial test loads to an inclined pile, the Engineer may elect to use axial test results from a nearby vertical pile to evaluate the axial capacity of the inclined pile.

NOTE 1—The quality of the result produced by this test method is dependent on the competence of the personnel performing it, and the suitability of the equipment and facilities used. Agencies that meet the criteria of Practice **D3740** are generally considered capable of competent and objective testing/sampling/ inspection/etc. Users of this test method are cautioned that compliance with Practice **D3740** does not in itself assure reliable results. Reliable results depend on many factors; Practice **D3740** provides a means of evaluating some of those factors.

5. Test Foundation Preparation

5.1 Excavate or add fill to the ground surface around the test pile or pile group to the final design elevation unless otherwise approved by the Engineer.

5.2 Cut off or build up the test pile as necessary to permit construction of the load-application apparatus, placement of the necessary testing and instrumentation equipment, and observation of the instrumentation. Remove any damaged or unsound material from the pile top and prepare the surface so that it is perpendicular to the pile axis with minimal irregularity to provide a good bearing surface for a test plate.

5.3 For tests of single piles, install a solid steel test plate at least 25 mm [1 in.] thick perpendicular to the long axis of the test pile that covers the complete pile top area. The test plate shall span across and between any unbraced flanges on the test pile.

5.4 For tests on pile groups, cap the pile group with steel-reinforced concrete or a steel load frame designed for the anticipated loads. Provide a clear space beneath the pile cap as specified by the Engineer to eliminate any bearing on the underlying ground surface. For each loading point on the pile cap, provide a solid steel test plate oriented perpendicular to the axis of the pile group with a minimum thickness of 25 mm [1 in.], as needed to safely apply load to the pile cap. Center a single bearing plate on the centroid of the pile group. Locate multiple bearing plates symmetrically about the centroid of the pile group. Boxes and beams may bear directly on the pile cap when designed to bear uniformly along their contact surface with the cap.

5.5 To minimize stress concentrations due to minor irregularities of the pile top surface, set test plates bearing on the top of precast or cast-in-place concrete piles in a thin layer of

³ Available from American Society of Mechanical Engineers (ASME), ASME International Headquarters, Three Park Ave., New York, NY 10016-5990, <http://www.asme.org>.

quick-setting, non-shrink grout, less than 6 mm [0.25 in.] thick and having a compressive strength greater than the test pile at the time of the test. Set test plates, boxes, and beams designed to bear on a concrete pile cap in a thin layer of quick-setting, non-shrink grout, less than 6 mm [0.25 in.] thick and having a compressive strength greater than the pile cap at the time of the test. For tests on steel piles, or a steel load frame, weld the test plate to the pile or load frame. For tests on individual timber piles, set the test plate directly on the cleanly cut top of the pile, or in grout as described for concrete piles.

NOTE 2—Deep foundations sometimes include hidden defects that may go unnoticed prior to the static testing. Low strain integrity tests as described in D5882 and ultrasonic crosshole integrity tests as described in D6760 may provide a useful pre-test evaluation of the test foundation.

6. Apparatus for Applying and Measuring Loads

6.1 General:

6.1.1 The apparatus for applying compressive loads to a test pile or pile group shall conform to one of the methods described in 6.3–6.6 Unless otherwise specified by the Engineer, the apparatus for applying and measuring loads described in this section shall be capable of safely applying at least 120 % of the maximum anticipated test load. Use the method described in 6.3 to apply axial loads to either vertical or inclined piles or pile groups. Use the methods described in 6.4–6.6 to apply only vertical loads.

6.1.2 Align the test load apparatus with the longitudinal axis of the pile or pile group to minimize eccentric loading. When necessary to prevent lateral deflection and buckling along the unsupported pile length, provide lateral braces that do not influence the axial movement of the pile, or pile cap.

6.1.3 Each jack shall include a hemispherical bearing or similar device to minimize lateral loading of the pile or group. The hemispherical bearing should include a locking mechanism for safe handling and setup. Center bearing plates, hydraulic jack(s), load cell(s), and hemispherical bearings on the test beam(s), test pile, or test pile cap.

6.1.4 Provide bearing stiffeners as needed between the flanges of test and reaction beams. Provide steel bearing plates as needed to spread the load from the outer perimeter of the jack(s), or the bearing surface of beams or boxes, to bear on the surface of the test pile or pile cap. Also provide steel bearing plates to spread the load between the jack(s), load cells, and hemispherical bearings, and to spread the load to the test beam(s), test pile, or pile cap. Bearing plates shall extend the full flange width of steel beams and the complete top area of piles, or as specified by the Engineer, so as to provide full bearing and distribution of the load.

6.1.5 Unless otherwise specified, provide steel bearing plates that have a total thickness adequate to spread the bearing load between the outer perimeters of loaded surfaces at a maximum angle of 45 ° to the loaded axis. For center hole jacks and center hole load cells, also provide steel plates adequate to spread the load from their inner diameter to the their central axis at a maximum angle of 45 °, or per manufacturer recommendations. Bearing plates shall extend the full width of the test beam(s) or any steel reaction members so as to provide full bearing and distribution of the load.

6.1.6 A qualified engineer shall design and approve all loading apparatus, loaded members, support frames, and loading procedures. The test beam(s), load platforms, and support structures shall have sufficient size, strength, and stiffness to prevent excessive deflection and instability up to the maximum anticipated test load.

NOTE 3—Rotations and lateral displacements of the test pile or pile cap may occur during loading, especially for piles extending above the soil surface or through weak soils. Design and construct the support reactions to resist any undesirable rotations or lateral displacements

6.2 Hydraulic Jacks, Gages, Transducers, and Load Cells:

6.2.1 The hydraulic jack(s) and their operation shall conform to ASME B30.1 Jacks and shall have a nominal load capacity exceeding the maximum anticipated jack load by at least 20 %. The jack, pump, and any hoses, pipes, fittings, gages, or transducers used to pressurize it shall be rated to a safe pressure corresponding to the nominal jack capacity.

6.2.2 The hydraulic jack ram(s) shall have a travel greater than the sum of the anticipated maximum axial movement of the pile plus the deflection of the test beam and the elongation and movement of any anchoring system, but not less than 15 % of the average pile diameter or width. Use a single high-capacity jack when possible. When using a multiple jack system, provide jacks of the same make, model, and capacity, and supply the jack pressure through a common manifold. Fit the manifold and each jack with a pressure gage to detect malfunctions and imbalances.

6.2.3 Unless otherwise specified, the hydraulic jack(s), pressure gage(s), and pressure transducer(s) shall have a calibration to at least the maximum anticipated jack load performed within the six months prior to each test or series of tests. Furnish the calibration report(s) prior to performing a test, which shall include the ambient temperature and calibrations performed for multiple ram strokes up to the maximum stroke of the jack.

6.2.4 Each complete jacking and pressure measurement system, including the hydraulic pump, should be calibrated as a unit when practicable. The hydraulic jack(s) shall be calibrated over the complete range of ram travel for increasing and decreasing applied loads. If two or more jacks are to be used to apply the test load, they shall be of the same make, model, and size, connected to a common manifold and pressure gage, and operated by a single hydraulic pump. The calibrated jacking system(s) shall have accuracy within 5 % of the maximum applied load. When not feasible to calibrate a jacking system as a unit, calibrate the jack, pressure gages, and pressure transducers separately, and each of these components shall have accuracy within 2 % of the applied load.

6.2.5 Pressure gages shall have minimum graduations less than or equal to 1 % of the maximum applied load and shall conform to ASME B40.100 Pressure Gages and Gauge Attachments with an accuracy grade 1A having a permissible error ± 1 % of the span. Pressure transducers shall have a minimum resolution less than or equal to 1 % of the maximum applied load and shall conform to ASME B40.100 with an accuracy grade 1A having a permissible error ± 1 % of the span. When used for control of the test, pressure transducers shall include a real-time display.

6.2.6 If the maximum test load will exceed 900 kN [100 tons], place a properly constructed load cell or equivalent device in series with each hydraulic jack. Unless otherwise specified the load cell(s) shall have a calibration to at least the maximum anticipated jack load performed within the six months prior to each test or series of tests. The calibrated load cell(s) or equivalent device(s) shall have accuracy within 1 % of the applied load, including an eccentric loading of up to 1 % applied at an eccentric distance of 25 mm [1 in.]. After calibration, load cells shall not be subjected to impact loads. A load cell is recommended, but not required, for lesser load. If not practicable to use a load cell, include embedded strain gages located in close proximity to the jack to confirm the applied load.

6.2.7 Do not leave the hydraulic jack pump unattended at any time during the test. Automated jacking systems shall include a clearly marked mechanical override to safely reduce hydraulic pressure in an emergency.

6.3 *Load Applied by Hydraulic Jack(s) Acting Against Anchored Reaction Frame (See Fig. 1 and Fig. 2):*

6.3.1 Apply the test load to the pile or pile group with the hydraulic jack(s) reacting against the test beam(s) centered over the test pile, or pile group. Install a sufficient number of anchor piles or suitable anchoring device(s) to provide adequate reactive capacity for the test beam(s). Provide a clear distance from the test pile or pile group of at least five times the maximum diameter of the largest anchor or test pile(s), but not less than 2.5 m [8 ft]. The Engineer may increase or decrease this minimum clear distance based on factors such as the type and depth of reaction, soil conditions, and magnitude of loads so that reaction forces do not significantly effect the test results.

NOTE 4—Excessive vibrations during anchor pile installation in non-

cohesive soils may affect test results. Anchor piles that penetrate deeper than the test pile may affect test results. Install the anchor piles nearest the test pile first to help reduce installation effects.

6.3.2 Provide sufficient clearance between the bottom flange(s) of the test beam(s) and the top of the test pile or pile group to place the necessary bearing plates, hydraulic jack(s), hemispherical bearing, and load cell(s). For test loads of high magnitude requiring several anchors, a steel framework may be required to transfer the applied loads from the test beam(s) to the anchors.

6.3.3 When testing individual inclined piles, align the jack(s), test beam(s), and anchor piles with the inclined longitudinal axis of the test pile.

6.3.4 Attach the test beam(s) (or reaction framework if used) to the anchoring devices with connections designed to adequately transfer the applied loads to the anchors so as to prevent slippage, rupture or excessive elongation of the connections under maximum required test load.

6.4 *Load Applied by Hydraulic Jack(s) Acting Against a Weighted Box or Platform (Fig. 3):*

6.4.1 Apply the test load to the pile or pile group with the hydraulic jack(s) reacting against the test beam(s) centered over the test pile, or pile group. Center a box or platform on the test beam(s) with the edges of the box or platform parallel to the test beam(s) supported by cribbing or piles placed as far from the test pile or pile group as practicable, but in no case less than a clear distance of 1.5 m [5 ft]. If cribbing is used, the bearing area of the cribbing at ground surface shall be sufficient to prevent adverse settlement of the weighted box or platform.

6.4.2 The test beam(s) shall have sufficient size and strength to prevent excessive deflection under the maximum load, and sufficient clearance between the bottom flange(s) of the test

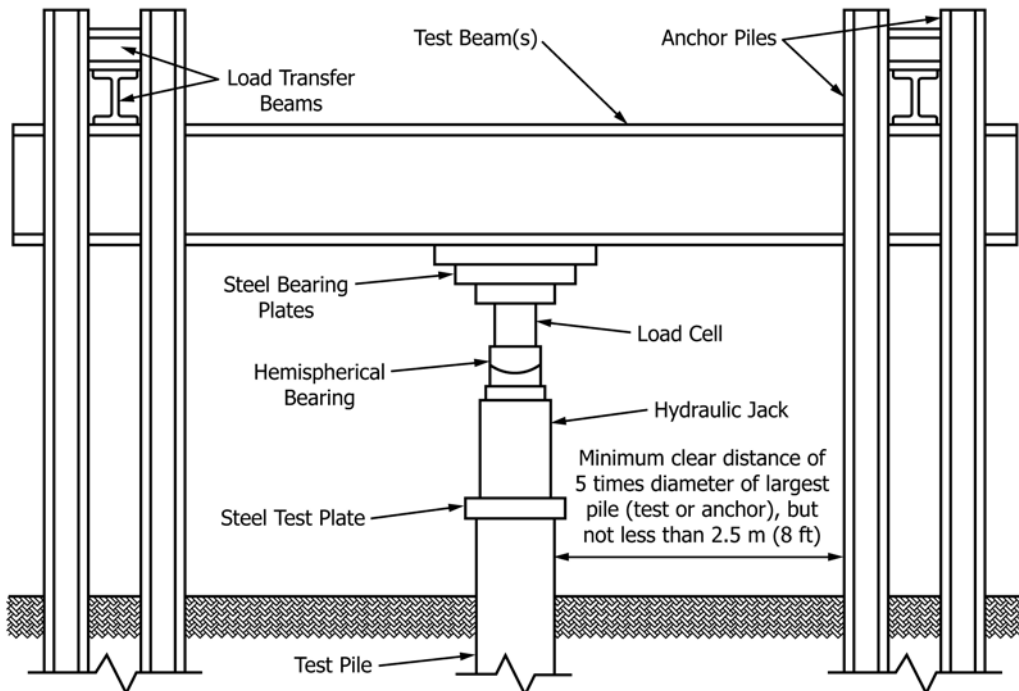

FIG. 1 Schematic of Hydraulic Jack Acting Against Anchored Reaction Frame

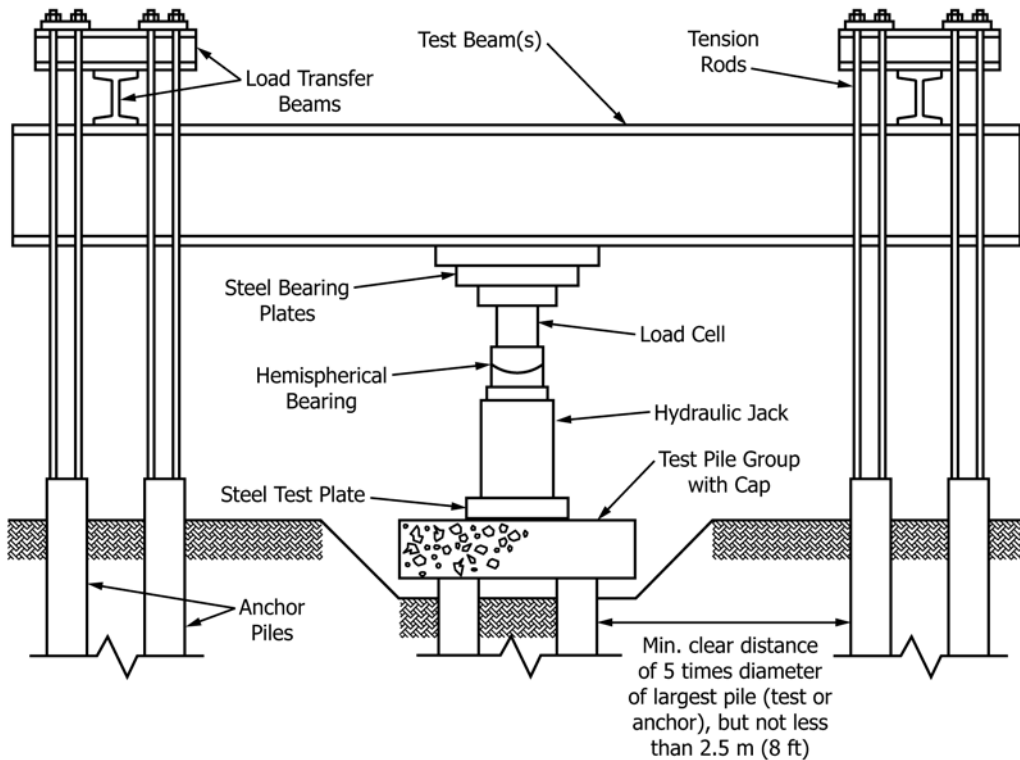

FIG. 2 Schematic of Hydraulic Jack on a Pipe Group Acting Against Anchored Reaction Frame

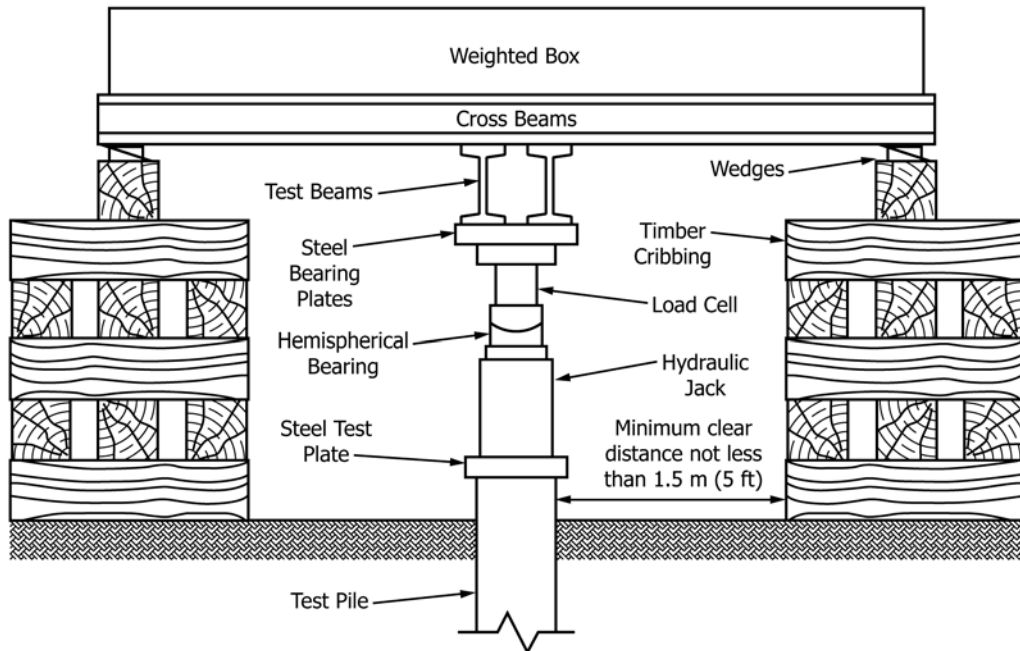

FIG. 3 Schematic Hydraulic Jack Acting Against Weighted Box or Platform

beam(s) and the top of the test pile or pile group to place the necessary bearing plates, hydraulic jack(s), hemispherical bearing, and load cell(s). Support the ends of the test beam(s) on temporary cribbing or other devices.

6.4.3 Load the box or platform with any suitable material such as soil, rock, concrete, steel, or water-filled tanks with a

total weight (including that of the test beam(s) and the box or platform) at least 10 % greater than the maximum anticipated test load.

6.5 Load Applied Directly Using Known Weights (See Fig. 4, Fig. 5, and Fig. 6):

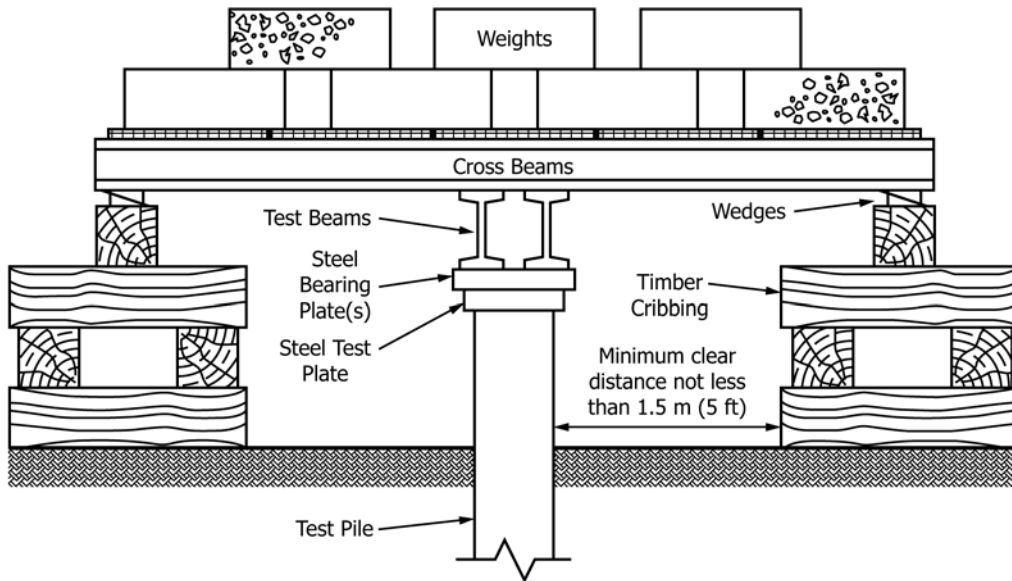

FIG. 4 Schematic of Direct Loading on a Single Pile Using Weighted Platform

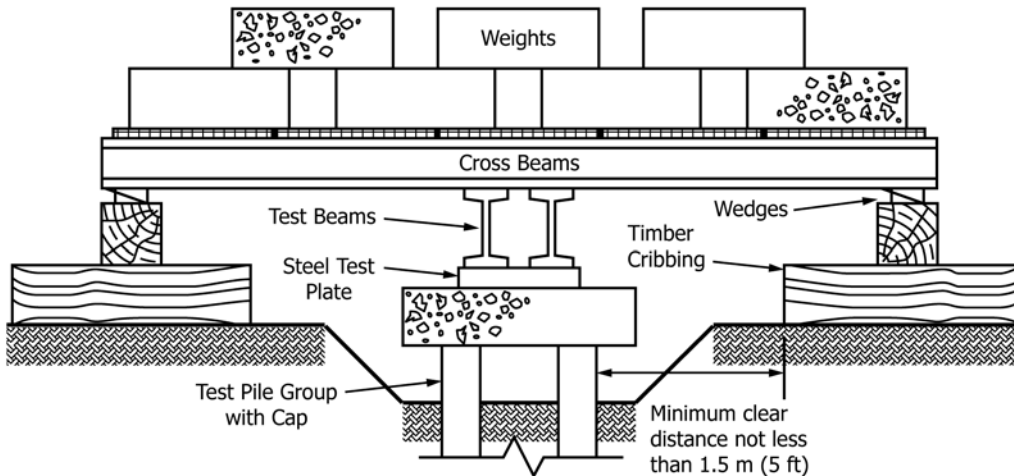

FIG. 5 Schematic of Direct loading on a Pile Group Using a Weighted Platform

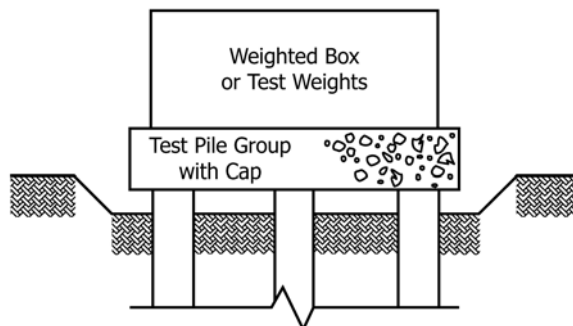

FIG. 6 Schematic of Direct Loading on a Pile Group

6.5.1 Center on the test pile or pile cap a test beam(s) of known weight and of sufficient size and strength to avoid excessive deflection under load with the ends supported on temporary cribbing if necessary to stabilize the beam(s).

Alternatively, the known test weights or loading material may be applied directly on the pile or pile cap.

6.5.2 Center and balance a platform of known weight on the test beam(s) or directly on the pile cap with overhanging edges

of the platform parallel to the test beam(s) supported by cribbing or by piles capped with timber beams, so that a clear distance of not less than 1.5 m [5 ft] is maintained between the supports and the test pile or pile group.

6.5.3 Place sufficient pairs of timber wedges between the top of the cribbing or timber cap beams and the bottom edges of the platform so that the platform can be stabilized during loading or unloading.

6.5.4 Apply the test loads to the pile or pile group using known weights. When loading the platform, remove any temporary supports at the ends of the test beam(s) and tighten the wedges along the bottom edges of the platform so that the platform is stable. Use loading materials such as steel or concrete so that the weight of incremental loads can be determined with accuracy of 5 %.

NOTE 5— Depending on the magnitude of the applied load and axial movement, platform stability may be difficult to control at or near a failure load when applying the load directly. The user should consider using a different load method when anticipating a failure load.

NOTE 6—The loading apparatus described in 6.5 may allow target rod level readings directly on the center of the pile top or pile cap to measure the pile top movement described in 7.2.4. To accommodate the target rod, use a double test beam with sufficient space between the beams, leave a hole through the platform, and leave a line of sight between the test weights for survey level readings.

6.6 *Other Types of Loading Apparatus (Optional)*—The Engineer may specify another type of loading apparatus satisfying the basic requirements of 6.3 or 6.4.

7. Apparatus for Measuring Movement

7.1 General:

7.1.1 Reference beams and wirelines shall be supported independent of the loading system, with supports firmly embedded in the ground at a clear distance from the test pile of at least five times the diameter of the test pile(s) but not less than 2.5 m [8 ft], and at a clear distance from any anchor piles of at least five times the diameter of the anchor pile(s) but not less than 2.5 m [8 ft]. Reference supports shall also be located as far as practicable from any cribbing supports but not less than a clear distance of 2.5 m [8 ft].

7.1.2 Reference beams shall have adequate strength, stiffness, and cross bracing to support the test instrumentation and minimize vibrations that may degrade measurement of the pile movement. One end of each beam shall be free to move laterally as the beam length changes with temperature variations. Supports for reference beams and wirelines shall be isolated from moving water and wave action. Provide a tarp or shelter to prevent direct sunlight and precipitation from affecting the measuring and reference systems.

7.1.3 Dial and electronic displacement indicators shall conform to ASME B89.1.10.M and should generally have a travel of 100 mm [4 in.], but shall have a minimum travel of at least 50 mm [2 in.]. Provide greater travel, longer stems, or sufficient calibrated blocks to allow for greater travel if anticipated. Electronic indicators shall have a real-time display of the movement available during the test. Provide a smooth bearing surface for the indicator stem perpendicular to the direction of stem travel, such as a small, lubricated, glass plate glued in place. Except as required in 7.4, indicators shall have minimum

graduations of 0.25 mm [0.01 in.] or less, with similar accuracy. Scales used to measure pile movements shall have a length no less than 150 mm [6 in.], minimum graduations of 0.5 mm [0.02 in.] or less, with similar accuracy, and shall be read to the nearest 0.1 mm [0.005 in.]. Survey rods shall have minimum graduations of 1 mm [0.01 ft] or less, with similar accuracy, and shall be read to the nearest 0.1 mm [0.001 ft].

7.1.4 Dial indicators and electronic displacement indicators shall be in good working condition and shall have a full range calibration within three years prior to each test or series of tests. Furnish calibration reports prior to performing a test, including the ambient air temperature during calibration

7.1.5 Clearly identify each displacement indicator, scale, and reference point used during the test with a reference number or letter.

7.1.6 Indicators, scales, or reference points attached to the test pile, pile cap, reference beam, or other references shall be firmly affixed to prevent movement relative to the test pile or pile cap during the test. Unless otherwise approved by the Engineer, verify that reference beam and wireline supports do not move during the test by using a surveyor's level to take readings on a survey rod or a scale with reference to a permanent bench mark located outside of the immediate test area.

7.2 Pile Top Axial Movements (See Fig. 7):

7.2.1 Unless otherwise specified, all axial compressive load tests shall include apparatus for measuring the axial movement of the test pile top, or piles within a group, or the pile group cap. This apparatus shall include a primary measurement system and at least one redundant, secondary system, using at least two of the systems described herein.

NOTE 7—When possible use displacement indicators as the primary system to obtain the most precise measurements. Use the redundant system(s) to check top movement data and provide continuity when the measuring system is disturbed or reset for additional movement.

NOTE 8—Pile top movements measured directly on the test pile have superior accuracy to measurements on the test plate, but with negligible difference when using a thin layer of grout on a sound pile, or with a test plate welded to the pile. However, users may wish to verify that the test plate and pile top do not move relative to each other using additional indicators (Fig. 7).

7.2.2 *Displacement Indicators*—Mount a minimum of two displacement indicators on the reference beams to bear on the pile top at axisymmetric points equidistant from the center of the test pile, or pile cap, with stems parallel to the longitudinal axis of the pile, inclined pile, or pile group. Orient two parallel reference beams, one on each side of the test pile or pile cap, in a direction that permits placing their supports as far as feasible from anchor piles or cribbing. Alternatively, mount the two indicators on axisymmetric points equidistant from the center of the test pile, or pile cap, with the stems parallel to the longitudinal axis of the pile or pile group to bear on the reference beams.

NOTE 9—For piles having a width or diameter greater than 0.75 m [2.5 ft], and for piles without good lateral support near the top, use four displacement indicators to compensate for lateral movement or rotation of the pile top.

NOTE 10—For tests on inclined piles, monitor lateral pile movements as

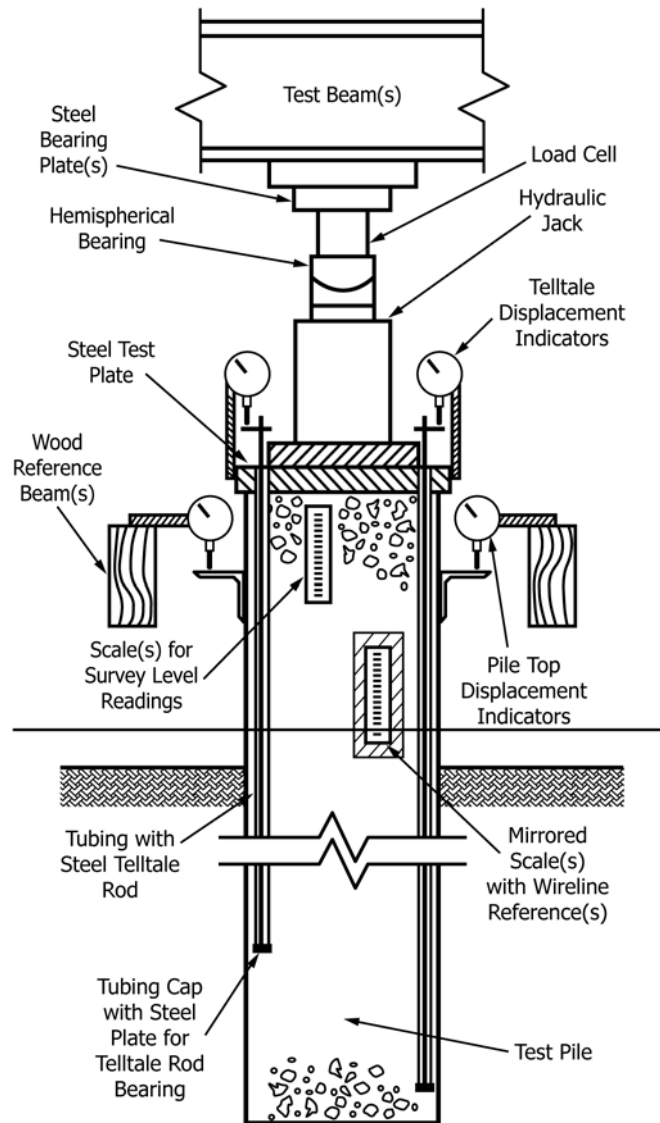

FIG. 7 Schematic of Instrumentation of Measuring Axial Pile Movements

described in 7.3 to detect instability that may result from gravitational forces during the test.

7.2.3 *Wireline, Mirror, and Scale*—Orient two wirelines parallel to each other and perpendicular to and located on opposite sides equidistant from the axis of the test pile, or pile group, in a direction that permits placing the wireline supports as far as practicable from anchor piles or cribbing. The wirelines shall include a weight or spring to maintain a constant tension force in the wire, so that, when plucked or tapped, the wireline will return to its original position. Use clean, uncoated steel wire with a diameter of 0.25 mm [0.01 in.] or less for the wirelines. Each wireline shall pass across, and remain clear of, a scale mounted on the test pile or pile cap parallel to the axis of the pile or pile group. Mount the scale on a mirror affixed to the test pile or pile cap and use the wireline as a reference line to read the scale. Use the mirror to eliminate parallax error in the scale reading by lining up the wire and its image in the mirror. Align the wire not more than 13 mm [0.5 in.] from the face of the scale.

7.2.4 *Surveyor's Level or Laser Beam*—Movement readings obtained using a surveyor's level or laser beam shall be taken on a survey rod or a scale and shall be referenced to a permanent bench mark located outside of the immediate test area or, alternatively, the surveyor's level shall be mounted on an object of fixed elevation (for example a driven pile) outside of the immediate test area. Reference points or scales used in taking displacement readings shall be mounted on the sides of the test pile or pile cap and located on opposite sides except that reference points may be located on top of the pile cap or readings may be taken on a single fixed point in the center of the test pile top, test plate or pile cap (see Fig. 6).

7.2.5 *Other Types of Measurement Systems (Optional)*—The Engineer may specify another type of measurement system satisfying the basic requirements of 7.2.

7.3 *Lateral Movements (Optional)*—Measure the lateral movements of the top of the test pile or pile group to within an accuracy of 2.5 mm [0.1 in.] using either of the following

methods: (a) two displacement indicators oriented in orthogonal directions, mounted with their stems perpendicular to the longitudinal axis of the test pile(s) and bearing against lubricated glass plates affixed to the sides of the test pile or pile cap, or (b) a surveyor's transit reading from scales mounted laterally on two perpendicular sides of the test pile or pile cap with readings referenced to fixed foresights or backsights. For tests on inclined piles, orient the indicators or scales parallel and perpendicular to the vertical plane of the incline and perpendicular to the longitudinal axis of the test pile(s).

7.4 *Pile Compression and Strain Measurements (Optional):*

7.4.1 Measure the compression or strain of the test pile during loading at locations specified by the Engineer to help evaluate the distribution of load transfer from the pile to the surrounding soil.

7.4.2 Determine pile compression using displacement indicators to measure the relative movement between the pile top and an unstrained telltale rod (Figs. 7-10) bearing at a point within the pile. Unless located on the pile axis, install paired telltales in the pile with the rods in each pair oriented symmetrically opposite each other and equidistant from and parallel to the pile axis. Terminate telltale pairs near the pile bottom and at other points along the pile as required. Measure and record the distance from the pile top to the telltale termination point(s) to the nearest 10 mm [0.5 in.]. Install the telltales in a sheath or casing to insure free rod movement during the test. The rods shall have a rounded tip that bears on a clean steel plate affixed to the pile or shall be threaded into a nut affixed to the pile. Clean the telltale rods prior to installation, oil them during or after installation, and provide centralizers to restrain lateral movement but not axial movement at the pile top. The displacement indicators shall have a travel of at least a 5 mm [0.2 in.] and minimum graduations of 0.01 mm [0.0001 in.] or less, with similar accuracy. Mount a smooth bearing surface for the indicator stem on the telltale rod perpendicular to the direction of stem travel, such as a small, lubricated, glass plate clamped or glued in place.

7.4.3 *Other types of telltale (Optional)*—The Engineer may specify another type of telltale for the measurement of pile compression that satisfies the basic requirements of 7.4.2.

7.4.4 Measure pile strain directly using strain gages installed along the length of the pile axis. Install single gages along the pile axis, or gage pairs with the gages in each pair oriented symmetrically opposite each other and equidistant from and parallel to the pile axis. Measure and record the distance from the pile top to the gages to the nearest 10 mm [0.5 in.]. The gage type and installation shall be as specified by the Engineer and shall include temperature compensation as recommended by the gage manufacturer. Where feasible, measurement programs involving strain gages should include calibration of the fully instrumented pile and a complete history of gage readings starting before their installation in the pile.

NOTE 11—To interpret strain measurements and estimate pile stresses, the Engineer will require a depth profile describing the variation of pile constituents and their strength, cross sectional area, and stiffness. Stiffness properties may vary with the applied stress, especially for grout or concrete. Obtain this information from installation records and separate

material property tests as needed.

8. Procedure

8.1 *Loading:*

8.1.1 *General:*

8.1.1.1 Apply test loads following one of the procedures described below for each test method, or as modified by the Engineer. If feasible, the maximum applied load should reach a failure that reflects the ultimate axial static compressive load capacity of the pile(s). Do not exceed the safe structural capacity of the pile or pile group, or the loading apparatus. Do not leave a loaded pile unattended.

8.1.1.2 To avoid excessive creep and possible structural failure of cast-in-place concrete piles, delay load testing after concrete placement to permit the fresh concrete to gain adequate strength and stiffness. Use test cylinders or cores of the pile concrete to determine the appropriate wait time, recognizing that the test cylinders will generally cure more quickly than concrete in the pile.

8.1.1.3 The static axial capacity of piles typically changes as time elapses after pile installation, possibly increasing (setup) or decreasing (relaxation), depending on the soil or rock properties and the pore water pressure and soil structure disturbance induced by installation. This behavior may affect both driven piles and cast-in-place piles. The Engineer may specify a waiting period between pile installation and static testing to investigate time effects. The waiting period may range from 3 to 30 days, or longer, based on testing (for example, re-driving piles) or prior experience.

8.1.1.4 When temporarily dewatering a test site with piles installed in granular soils, maintain the groundwater level as near to the nominal elevation as possible and record the elevation of the groundwater surface during the test. Use the groundwater surface elevation measured during the test to correct the axial pile capacity when the groundwater level during the test deviates more than 1.5 m [5 ft] from the service groundwater elevation.

8.1.2 *Procedure A: Quick Test*—Apply the test load in increments of 5 % of the anticipated failure load. Add each load increment in a continuous fashion and immediately following the completion of movement readings for the previous load interval. Add load increments until reaching a failure load but do not exceed the safe structural capacity of the pile, pile group, or loading apparatus. During each load interval, keep the load constant for a time interval of not less than 4 min and not more than 15 min, using the same time interval for all loading increments throughout the test. Remove the load in five to ten approximately equal decrements, keeping the load constant for a time interval of not less than 4 min and not more than 15 min, using the same time interval for all unloading decrements. Consider longer time intervals for the failure load to assess creep behavior and for the final zero load to assess rebound behavior.

8.1.3 *Procedure B: Maintained Test (Optional):*

8.1.3.1 Unless failure occurs first, load the pile to a maximum maintained load of 200 % of the anticipated design load for tests on individual piles, or 150 % of the pile group design load, applying the load in increments of 25 % of the design load. Maintain each load increment until the rate of axial

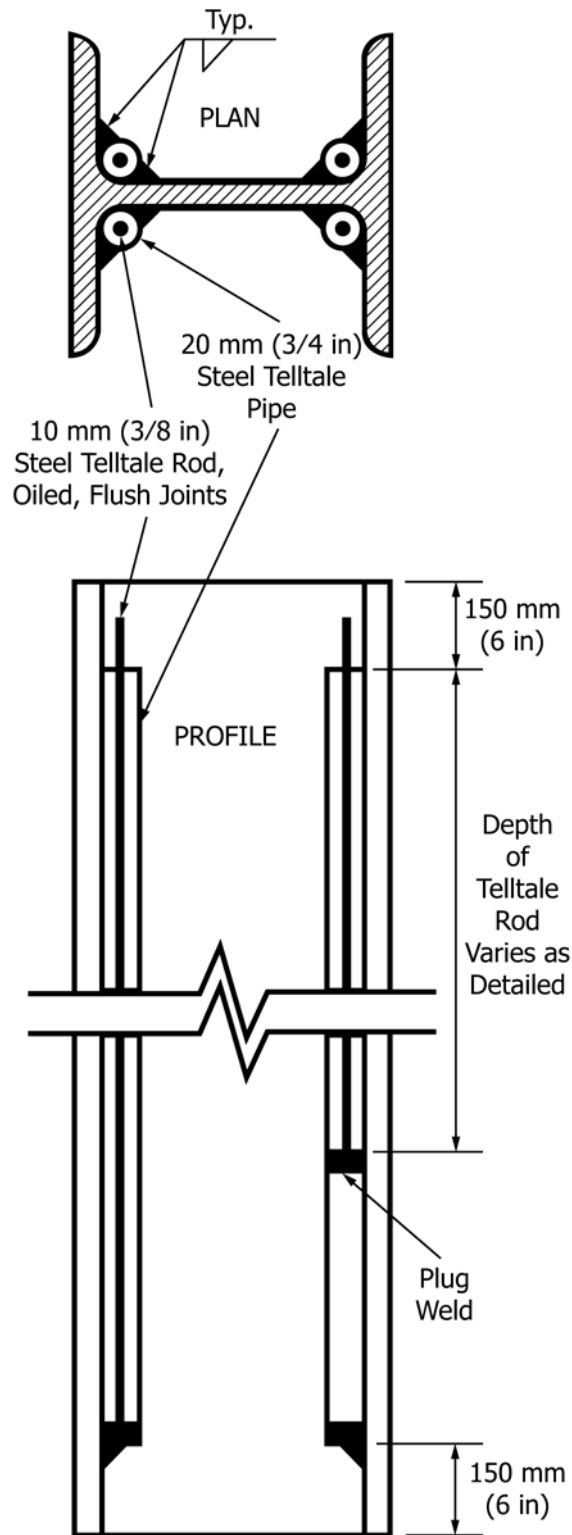

Note: Install Telltale Rods After Driving Pile

FIG. 8 Possible Installation of Telltales for Steel H-Piles

movement does not exceed 0.25 mm [0.01 in.] per hour, with a minimum time adequate to verify this movement rate based on the accuracy of the movement indicator readings, and with a maximum of 2 hr. After applying the maximum load and

reaching an overall test duration of at least 12 hr, begin unloading when the axial movement measured over a period of 1 hr does not exceed 0.25 mm [0.01 in.]; otherwise allow the maximum load to remain on the pile or pile group for 24 hr. If

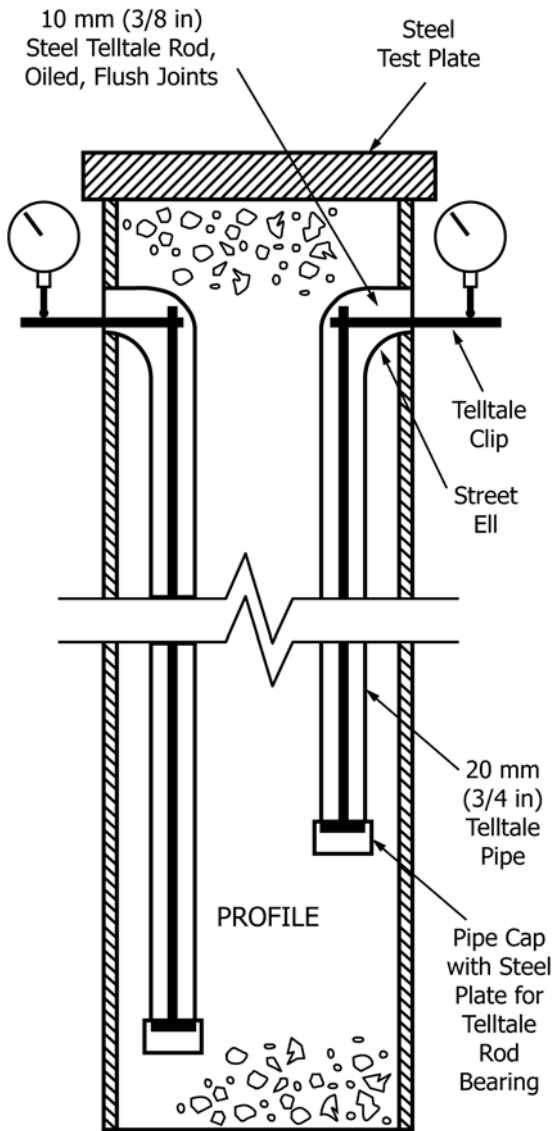

Note: Install Telltale Pipes, Install Telltale Rods, and Fill Pipe with Concrete After Driving

FIG. 9 Possible Installation of Telltales for Pipe Piles

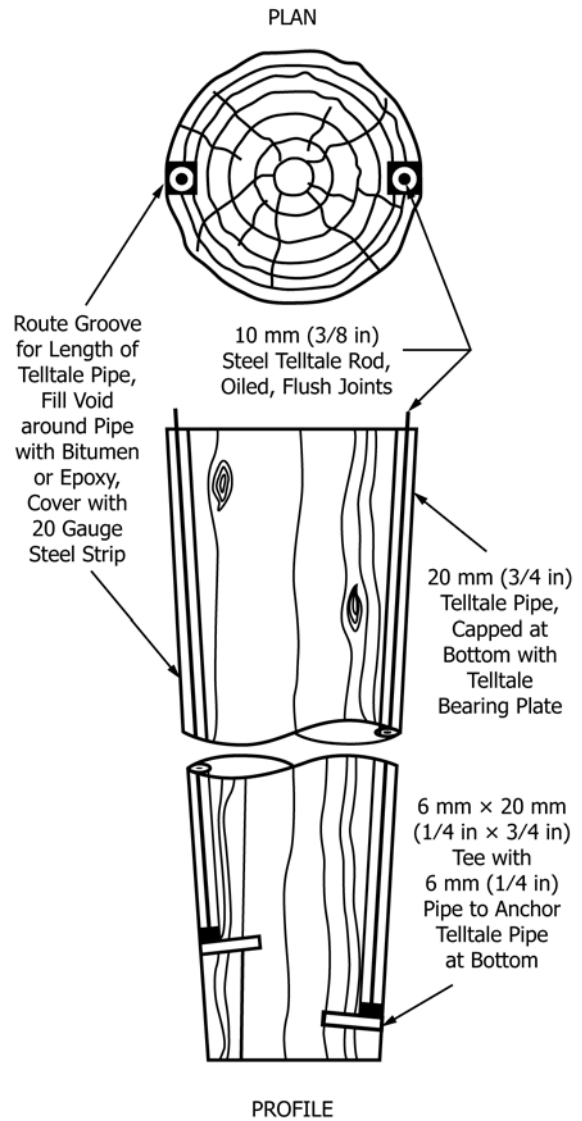

Note: Install Telltale Rods After Driving

FIG. 10 Possible Installation of Telltales for Timber Piles

failure occurs during loading, maintain the failure load, or the maximum load possible, until the total axial movement equals 15 % the pile diameter or width. After completing the final load increment, remove the load in decrements of 25 % of the maximum test load with 1 hr between decrements.

8.1.3.2 If using the direct loading method described in 6.5, include in the first load increment the weight of the test beam(s) and the platform that bear directly on the pile. Before adding or removing load increments, tighten the wedges along the platform edges to stabilize the platform. Place or remove load increments in a manner which avoids impact and maintains the load balanced at all times. After each load increment has been added, loosen (but do not remove) the wedges and keep them loose to permit the full load to act on the pile as it moves.

NOTE 12— If negligible permanent axial movement occurs after unloading the pile, consider reloading the test pile(s) to a greater load or use the procedure in Section 8.1.4. If the test pile(s) approach failure during the maintained loading procedure, consider decreasing the final load increments to obtain a more accurate failure load.

8.1.4 Procedure C: Loading in Excess of Maintained Test (Optional)—After the load has been applied and removed in accordance with 8.1.3, reload the test pile or pile group to the maximum maintained load in increments of 50 % of the pile or pile group design load, allowing 20 min between load increments. Then apply additional load in increments of 10 % of the design load for the pile or pile group until reaching the maximum required load or failure, allowing 20 min between load increments. If failure occurs continue jacking the pile until the settlement equals 15 % of the pile diameter or width. If failure does not occur, hold the full load for 2 hr and then remove the load in four equal decrements, allowing 20 min between decrements.

8.1.5 *Procedure D: Constant Time Interval Loading Test*—Follow the procedures of 8.1.3, but apply the load in increments of 20 % of the pile or group design load with 1 hr between load increments. Then unload the piles with 1 hr between load decrements.

8.1.6 *Procedure E: Constant Rate of Penetration Test (Optional)*:

8.1.6.1 The apparatus for applying loads shall have a capacity as specified and shall be in accordance with section 6.3 or 6.4. Use a mechanical hydraulic jacking system equipped with a bleed valve, variable speed device, or other means for providing a smooth variable pressure delivery.

8.1.6.2 Vary the applied load as necessary to maintain a pile penetration rate of 0.25 to 1.25 mm [0.01 to 0.05 in.] per minute for cohesive soil or 0.75 to 2.5 mm [0.03 to 0.10 in.] per minute for granular soils, or as specified by the Engineer. Continue loading the pile until achieving continuous penetration at the specified rate. Hold the maximum applied load until obtaining a total pile penetration of at least 15 % of the average pile diameter or width, or until the pile stops penetrating. Gradually release the final load to protect the load and measurement systems

8.1.6.3 Control the rate of penetration by checking the time taken for successive small equal increments of penetration and then adjusting the jacking accordingly. Alternatively, use a mechanical or electrical device to monitor and control the penetration rate so that it remains constant

8.1.6.4 See 7.2.5 for measurement procedures. When using a video recording system, locate all gages for easy reading within the camera's field of view, as well as a digital clock displaying time to the nearest second.

8.1.7 *Procedure F: Constant Movement Increment Test (Optional)*:

8.1.7.1 Apply test loads in increments required to produce pile top movement increments equal to approximately 1 % of the average pile diameter or width. Vary the applied load as necessary to maintain each movement increment, and do not apply additional load until the rate of load variation to hold that movement increment constant is less than 1 % of the total applied load per hour. Continue loading the pile in such increments until the total movement equals 15 % of the average pile diameter or width.

8.1.7.2 Remove the final test load in four equal decrements after maintaining the final movement increment until the rate of load variation is less than 1 % of the total applied load per hour. After removing the first load decrement, do not remove additional decrements until the rate of pile rebound for the preceding load decrement is less than 0.3 % of the average pile diameter or diagonal dimension per hour.

8.1.8 *Procedure G: Cyclic Loading Test (Optional)*—For the first application of test load increments, apply such increments in accordance with 8.1.3. After the application of loads equal to 50, 100 and 150 % of the pile design load for tests of individual piles or 50 and 100 % of the group design load for tests on pile groups, maintain the total test load in each case for 1 hr and remove the load in decrements equal to the loading increments, allowing 20 min between decrements. After removing each maximum applied load, reapply the load to each preceding load

level in increments equal to 50 % of the design load, allowing 20 min between increments. Apply additional loads in accordance with 8.1.3. After the maximum required test load has been applied, hold and remove the test load in accordance with 8.1.3.

8.2 *Recording Test Readings*:

8.2.1 *General*:

8.2.1.1 For the required time intervals described below for each test method, record the time, applied load, and movement readings (displacement, and strain if measured) for each properly identified gage, scale, or reference point taken as nearly simultaneously as practicable. The Engineer may specify different reading intervals from those given below as needed to satisfy the objectives of a particular test pile program. Obtain additional test readings as specified by the Engineer, or as convenient for testing purposes, i.e. when using a datalogger to record readings at a constant time interval. When using the loading procedure described in 6.5, take the zero-load reading before placing the test beam(s) and platform on the pile(s). Clearly record and explain any field adjustments made to instrumentation or recorded data.

8.2.1.2 Verify the stability of the reference beams and load reaction system (including reaction piles) using a surveyor's level or transit and target rod or scales to determine movement. Record readings taken before applying any test load, at the proposed design load, at the maximum test load, and after the removal of all load. Intermediate readings for each load increment are recommended to provide additional quality assurance and detect potential failure of the load reaction system.

8.2.1.3 When using embedded strain gages to obtain incremental strain measurements as in 7.4 record strain readings just before starting the test and, as a minimum, during the test whenever recording readings of time, load, and movement. The Engineer may also require gage readings taken before and after the pile installation to obtain a complete strain history and investigate residual stress behavior.

8.2.2 *Procedure A: Quick Test*—Record test readings taken at 0.5, 1, 2 and 4 min after completing the application of each load increment, and at 8 and 15 min when permitted by longer load intervals. Record test readings taken at 1 and 4 min after completing each load decrement, and at 8 and 15 min when permitted by a longer unload intervals. Record readings taken at 1, 4, 8 and 15 min after all load has been removed.

NOTE 13—The movement measured between readings for a given load increment provides an indication of creep behavior.

8.2.3 *Procedure B: Maintained Test (also Procedures C, D, and G) (Optional)*—Record test readings taken before and after the application of each load increment or decrement. During each load interval, provided that the test pile or pile group has not failed, record additional readings taken at 5, 10, and 20 min following application of the load increment, and every 20 min thereafter as needed. After applying the total load, provided that the test pile or pile group has not failed, record additional readings taken at 5, 10, and 20 min, then every 20 min up to 2 hrs, then every hour from 2 to 12 hrs, and then every 2 hrs from 12 to 24 hrs as needed. If pile failure occurs, also record

readings taken immediately before removing the first load decrement. During unloading, record readings taken at time intervals of 20 min. Record final readings 12 hr after removing all load.

8.2.4 Procedure E: Constant Rate of Penetration (Optional)—Record test readings taken at least every 30 s or at sufficient intervals to determine the actual rate of penetration. Operate any automatic monitoring and recording devices continuously during each test. When the test pile has achieved its specified rate of penetration, continue to take and record readings for the duration of the loading, and determine the maximum load applied. Take and record readings immediately after unloading and again 1 h after removing all load.

8.2.5 Procedure F: Constant Movement Increment (Optional)—Record test readings taken immediately before and after each movement increment with sufficient intermediate readings so as to determine the rate of load variation and the actual load required to maintain each settlement increment. During unloading, record readings taken immediately before and after the removal of each load decrement with sufficient intermediate readings so as to determine the rate of pile rebound. Record final readings taken 12 h after removing all load.

9. Safety Requirements

9.1 All operations in connection with pile load testing shall be carried out in such a manner so as to minimize, avoid, or eliminate the exposure of people to hazard. The following safety rules are in addition to general safety requirements applicable to construction operations:

9.1.1 Keep all test and adjacent work areas, walkways, platforms, etc. clear of scrap, debris, small tools, and accumulations of snow, ice, mud, grease, oil, or other slippery substances.

9.1.2 Provide timbers, blocking and cribbing materials made of quality material and in good serviceable condition with flat surfaces and without rounded edges.

9.1.3 Hydraulic jacks shall be equipped with spherical bearing plates or shall be in complete and firm contact with the bearing surfaces and shall be aligned so as to avoid eccentric loading.

9.1.4 Loads shall not be hoisted, swung, or suspended over anyone and shall be controlled by tag lines.

9.1.5 The test beam(s), reaction frame, anchor piles and other anchoring devices, test boxes, and their connections and supports shall be designed and approved by a qualified engineer and installed to transmit the required loads with an adequate factor of safety.

9.1.6 For tests on inclined piles, all inclined jacks, bearing plates, test beam(s), or frame members shall be firmly fixed into place or adequately blocked to prevent slippage upon release of load.

9.1.7 All reaction loads shall be stable and balanced. When using loading method in 6.5, safety wedges shall be in place at all times to prevent the platform from tipping. During testing, movements of the reaction load or system should be monitored to detect impending unstable conditions.

9.1.8 All test beams, reaction frames, platforms, and boxes shall be adequately supported at all times.

9.1.9 Only authorized personnel shall be permitted within the immediate test area, and only as necessary to monitor test equipment. As best as possible, locate pumps, load cell readouts, dataloggers, and test monitoring equipment at a safe distance away from jacks, loaded beams, weighted boxes, dead weights, and their supports and connections.

10. Report

10.1 The report of the load test shall include the following information as required by the Engineer and as appropriate to the pile type, test apparatus, and test method:

10.1.1 General:

10.1.1.1 Project identification and location,

10.1.1.2 Test site location,

10.1.1.3 Owner, structural engineer, geotechnical engineer, pile contractor, boring contractor,

10.1.1.4 Nearest test boring(s) or sounding(s), and their location with reference to test location,

10.1.1.5 Insitu and laboratory soil test results, and

10.1.1.6 Horizontal and vertical control datum.

10.1.2 Pile Installation Equipment:

10.1.2.1 Make, model, type and size of hammer,

10.1.2.2 Weight of hammer and ram,

10.1.2.3 Stroke or ram,

10.1.2.4 Rated energy of hammer,

10.1.2.5 Rated capacity of boiler or compressor,

10.1.2.6 Type and dimensions of capblock and pile cushion,

10.1.2.7 Weight and dimensions of drive cap and follower,

10.1.2.8 Size of predrilling or jetting equipment,

10.1.2.9 Weight of clamp, follower, adaptor, and oscillator for vibratory driver.

10.1.2.10 Type, size, length, and weight of mandrel,

10.1.2.11 Type, size, and length of auger,

10.1.2.12 Type and size of grout pump, and

10.1.2.13 Type, size, wall thickness, and length of drive casing.

10.1.2.14 Detailed description of drilling equipment and techniques,

10.1.2.15 Size, type, length, and installation or extraction method of casings or a combination thereof.

10.1.3 Test and Anchor Pile Details:

10.1.3.1 Identification and location of test and anchor piles,

10.1.3.2 Design load of test pile or pile group,

10.1.3.3 Type and dimensions of test and anchor piles

10.1.3.4 Test pile material including basic specifications,

10.1.3.5 Pile quality including knots, splits, checks and shakes, and straightness of piles, preservative treatment and conditioning process used for timber test piles including inspection certificates,

10.1.3.6 Wall thickness of pipe test pile,

10.1.3.7 Weight per foot of H test pile,

10.1.3.8 Description of test pile tip reinforcement or protection,

10.1.3.9 Description of banding—timber piles,

10.1.3.10 Description of special coatings used,

10.1.3.11 Test pile (mandrel) weight as driven,

- 10.1.3.12 Date precast test piles made,
- 10.1.3.13 Details of concrete and/or grout mix design,
- 10.1.3.14 Concrete and/or grout placement techniques and records ,
- 10.1.3.15 Concrete and/or grout sample strengths and date of strength test,
- 10.1.3.16 Description of internal reinforcement used in test pile (size, length, number longitudinal bars, arrangement, spiral, or tie steel),
- 10.1.3.17 Condition of precast piles including spalled areas, cracks, top surface, and straightness of piles.
- 10.1.3.18 Effective prestress,
- 10.1.3.19 Degree of inclination for each pile,
- 10.1.3.20 Length of test pile during driving,
- 10.1.3.21 Final pile top and bottom elevations, and ground elevation referenced to a datum,
- 10.1.3.22 Embedded length—test and anchor piles,
- 10.1.3.23 Tested length of test pile, and
- 10.1.3.24 Final elevation of test pile butt(s) referenced to fixed datum.
- 10.1.4 *Test and Anchor Pile Installation:*
 - 10.1.4.1 Date installed,
 - 10.1.4.2 Volume of concrete or grout placed in pile,
 - 10.1.4.3 Grout pressure used,
 - 10.1.4.4 Description of pre-excavation or jetting (depth, size, pressure, duration),
 - 10.1.4.5 Operating pressure for double-acting and differential type hammers,
 - 10.1.4.6 Throttle setting—diesel hammer (at final driving),
 - 10.1.4.7 Fuel type—diesel hammer,
 - 10.1.4.8 Horsepower delivered and frequency of vibratory driver during final 3 m [10 ft] of pile penetration,
 - 10.1.4.9 Description of special installation procedures used such as piles cased off,
 - 10.1.4.10 Type and location of pile splices,
 - 10.1.4.11 Driving or drilling records,
 - 10.1.4.12 Final penetration resistance (blows per centimetre [blows per inch]),
 - 10.1.4.13 Rate of pile penetration for last 3 m [10 ft] s/ft, vibratory driving,
 - 10.1.4.14 When capblock replaced (indicate on log),
 - 10.1.4.15 When pile cushion replaced (indicate on log),
 - 10.1.4.16 Cause and duration of interruptions in pile installation, and

10.1.4.17 Notation of any unusual occurrences during installation.

10.1.5 *Pile Testing:*

- 10.1.5.1 Date and type of test,
- 10.1.5.2 Temperature and weather conditions during tests,
- 10.1.5.3 Number of piles in group test,
- 10.1.5.4 Brief description of load application apparatus, including jack capacity,
- 10.1.5.5 Description of instrumentation used to measure pile movement including location of indicators, scales, and other reference points with respect to pile top,
- 10.1.5.6 Description of special instrumentation such as strain rods or strain gages including location of such with reference to pile top,
- 10.1.5.7 Special testing procedures used,
- 10.1.5.8 Tabulation of all time, load, and movement readings,
- 10.1.5.9 Identification and location sketch of all gages, scales, and reference points,
- 10.1.5.10 Description and explanation of adjustments made to instrumentation or field data, or both,
- 10.1.5.11 Notation of any unusual occurrences during testing,
- 10.1.5.12 Test jack and other required calibration reports,
- 10.1.5.13 Groundwater level, and
- 10.1.5.14 Suitable photographs showing the test instrumentation and set-up.

11. Precision and Bias

11.1 *Precision*—Test data on precision is not presented due to the nature of this test method. It is either not feasible or too costly at this time to have ten or more agencies participate in an in situ testing program at a given site

11.1.1 Subcommittee D18.11 is seeking any data from the users of this test method that might be used to make a limited statement on precision.

11.2 *Bias*—There is no accepted reference value for this test method, therefore, bias cannot be determined.

12. Keywords

12.1 axial static pile capacity; field testing; jack; load cell; loading procedure; reference beam

APPENDIX**(Nonmandatory Information)****X1. SOME FACTORS INFLUENCING INTERPRETATION OF TEST RESULTS**

X1.1 Potential residual loads in the pile which could influence the interpreted distribution of load at the pile tip and along the pile shaft.

X1.2 Possible interaction of friction loads from test pile with upward friction transferred to the soil from anchor piles obtaining part or all of their support in soil at levels above the tip level of the test pile.

X1.3 Changes in pore water pressure in the soil caused by pile driving, construction fill, and other construction operations which may influence the test results for frictional support in relatively impervious soils such as clay and silt.

X1.4 Differences between conditions at time of testing and after final construction such as changes in grade or groundwater level.

X1.5 Potential loss of soil supporting test pile from such things as excavation and scour.

X1.6 Possible differences in the performance of a pile in a group or of a pile group from that of a single isolated pile.

X1.7 Affect on long-term pile performance of factors such as creep, environmental effects on pile material, negative friction loads not previously accounted for, and strength losses.

X1.8 Type of structure to be supported, including sensitivity of structure to settlements and relation between live and dead loads.

X1.9 Special testing procedures which may be required for the application of certain acceptance criteria or methods of interpretation.

X1.10 Requirement that non tested pile(s) have essentially identical conditions to those for tested pile(s) including, but not limited to, subsurface conditions, pile type, length, size and stiffness, and pile installation methods and equipment so that application or extrapolation of the test results to such other piles is valid.

ASTM International takes no position respecting the validity of any patent rights asserted in connection with any item mentioned in this standard. Users of this standard are expressly advised that determination of the validity of any such patent rights, and the risk of infringement of such rights, are entirely their own responsibility.

This standard is subject to revision at any time by the responsible technical committee and must be reviewed every five years and if not revised, either reapproved or withdrawn. Your comments are invited either for revision of this standard or for additional standards and should be addressed to ASTM International Headquarters. Your comments will receive careful consideration at a meeting of the responsible technical committee, which you may attend. If you feel that your comments have not received a fair hearing you should make your views known to the ASTM Committee on Standards, at the address shown below.

This standard is copyrighted by ASTM International, 100 Barr Harbor Drive, PO Box C700, West Conshohocken, PA 19428-2959, United States. Individual reprints (single or multiple copies) of this standard may be obtained by contacting ASTM at the above address or at 610-832-9585 (phone), 610-832-9555 (fax), or service@astm.org (e-mail); or through the ASTM website (www.astm.org). Permission rights to photocopy the standard may also be secured from the Copyright Clearance Center, 222 Rosewood Drive, Danvers, MA 01923, Tel: (978) 646-2600; <http://www.copyright.com/>